

Standard executions		
Version	Symbol	Type
Magnetic Standard		AMT



1

For the magnetic reed switches type ASV see from page 1.110.1.
For coupling cylinders/reed switches/brackets see table on page 1.120.5
For mounting accessories see from page 1.97.1.
For rod accessories see from page 1.85.1.

II 2Gc IIC T5
II 2Dc T100°C

On request, they can be supplied according to 2014/34/EU - ATEX

New series of cylinders conforming to ISO 15552 standards. External tie-rods and round anodised aluminium tube. The main features of this cylinder are the modern design and the attention to details.

Options	Suffix
Through rod (page 1.8.4)	P
Rod in stainless steel AISI 304	K
Seals FKM -20°C ÷ +150°C	V
Scraper ring only FKM -20°C ÷ +80°C	V1
Low temperature seals -40°C ÷ +80°C	BT
Tandem forward movement piston rods coupled together (page 1.8.5)	TA1
Tandem forward movement piston rods independent (page 1.8.5)	TA2
Tandem back to back (page 1.8.5)	TA3
Tandem front to front (page 1.8.5)	TA4
Extended rod (indicate the requested WH dimension in mm. E.g.: WH -100)	WH-...
Without adjustable cushionings	D
Adjustable rear cushioning only	D1
Adjustable front cushioning only	D2
Special male thread (indicate the requested thread. E.g. : R-M 10x1,5). The dimension AM of the special thread will be the same as the standard. The cylinder will be supplied without rod nut.	R-M...
Female thread; for dimensions see page 1.8.4	F
With bellows for protection of the rod (in this case the dimension WH will be extended according the stroke of the cylinder)	Z
NBR seals	H
Piston rod tightness in nitrile rubber NBR with retainer ring	H1
Brass rod scraper (with V, V1 and H options only)	Y
Stainless steel AISI 316L profile tube	TX
Special on request	/S

The options can be combined (when this is possible).
The suffix of the options are to be added to the model number of the standard product, as shown in the following table.

How to order: 160 / 100 AMTKVR-M20x1,5

160	/	100	AMT	K	V	R-M20x1,5
Bore	/	Stroke	Type	Option	Option	Option

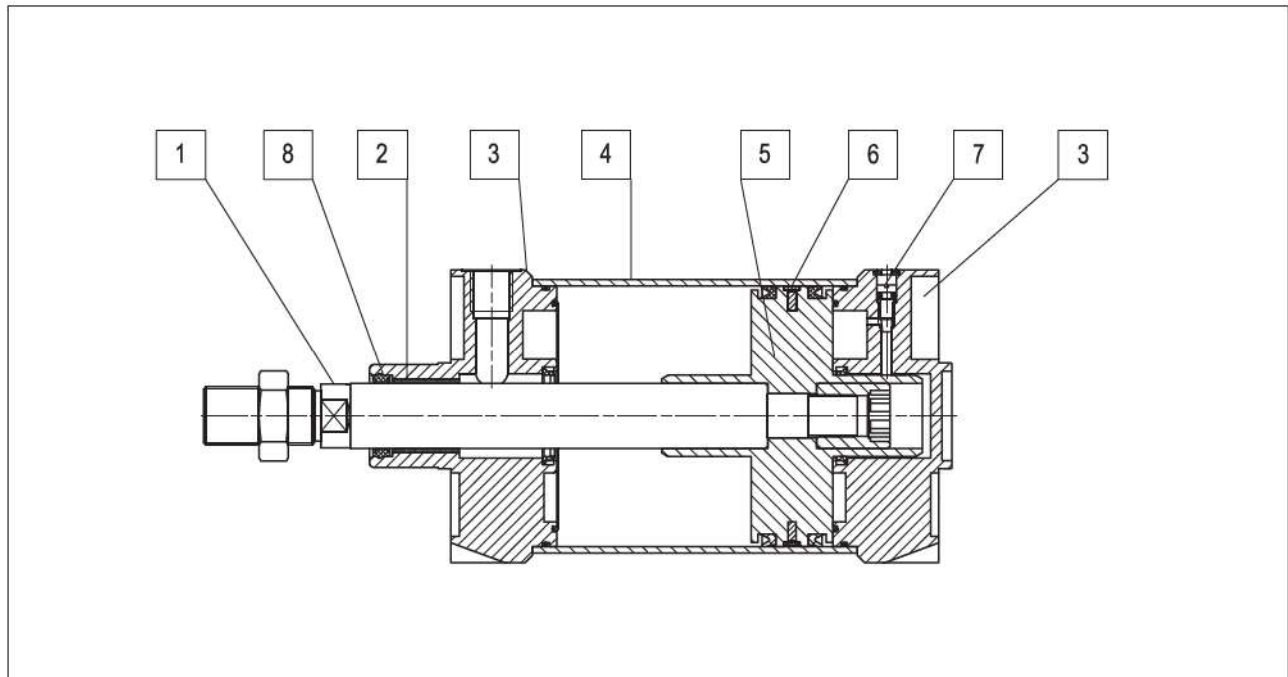

Materials (standard types)	
1 Rod	Chrome-plated steel C45
2 Bushing	Self-lubricating sintered bronze
3 Heads	Die-cast painted aluminium
4 Tube	Anodised aluminium
5 Piston	Die-cast aluminium
6 Guide ring	Natural Delrin
7 Cushioning adjustment screw	Stainless steel AISI 303
8 Rod seals	Polyurethane
Other seals	Nitrile rubber NBR/polyurethane

Technical data					
Bore (mm)	160	200	250	320	
Fluid	Compressed filtered air with or without lubrication. Lubrication, if started, must be continued.				
Pressure	1 ÷ 10 bar				
Temperature range	-20°C ÷ +80°C (standard / V1)	-20°C ÷ +150°C (V)	-40°C ÷ +80°C (BT)		
Stroke	from 10 mm to 2500 mm				
Cushion length	46	47	40	40	
Ports	3/4"		1"		
Rod thread	M36 x 2		M42 x 2	M48 x 2	
Weight	Stroke zero (g)	11507	14532	26811	47996
	Additional 10 mm stroke (g)	234	250	384	597

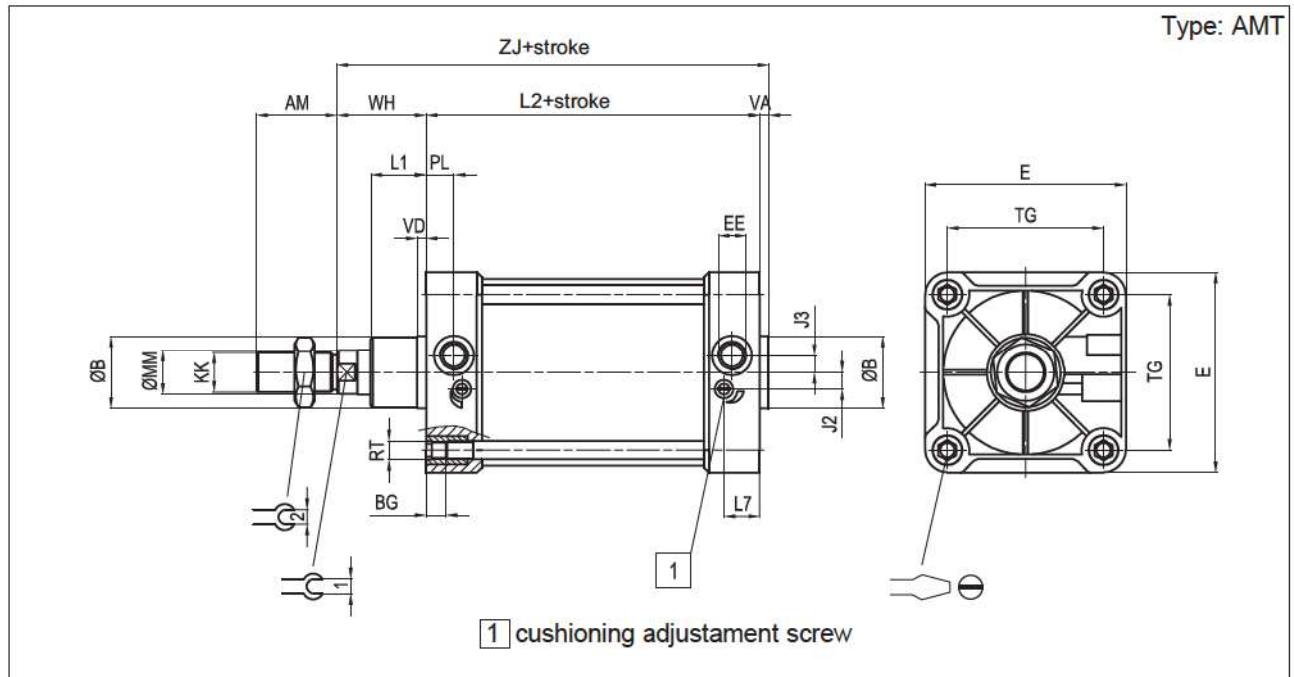

Ø (mm)	AM	B Ø d11	BG	E	EE	J2	J3	KK	L1	L2	H
160	72	65	24	180	3/4"	15	15	M36x2	50	180	14
200	72	75	24	220	3/4"	15	15	M36x2	65	180	14
250	84	90	25	270	1"	25	25	M42x2	75	200	20
320	96	110	30	350	1"	35	35	M48x2	90	220	17

Ø (mm)	L7	MM Ø f7	PL	RT	TG	VA	VD	WH	ZJ	⌀ 1	⌀ 2	⌀
160	32	40	25	M16	140	6	8	80	266	36	55	$\frac{25}{3,7}$
200	34	40	25	M16	175	6	25	95	281	36	55	$\frac{25}{3,7}$
250	40	50	30	M20	220	8	25	105	313	46	65	$\frac{32}{5,5}$
320	45	63	30	M24	270	10	25	120	350	55	75	$\frac{36}{5,5}$

Seals kits	
n. 1	Rod seal
n. 2	Cushioning seal
n. 2	Piston lip-seal
n. 1	Linear rubber ring for piston (damper)
n. 2	Tube O-ring
n. 1	Piston guiding ring
n. 2	O-ring for cushioning screw
n. 1	O-ring to seal two semi-pistons

How to order: 200 / SG / AMT

200	/	SG	/	AMT
Bore	/	Seal kit	/	Type

Type: ...P

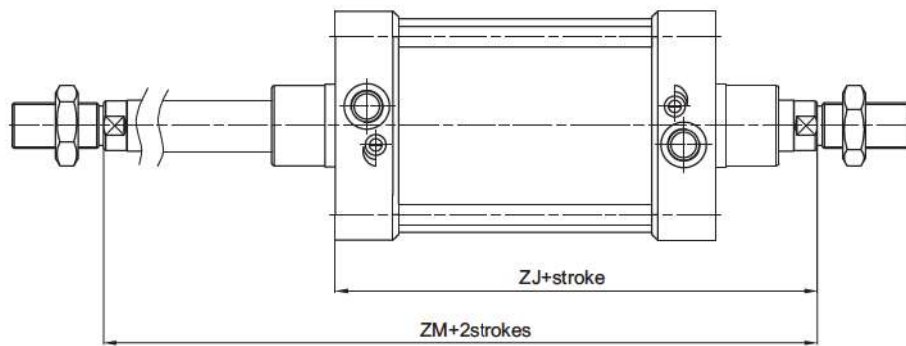

Type: ...F

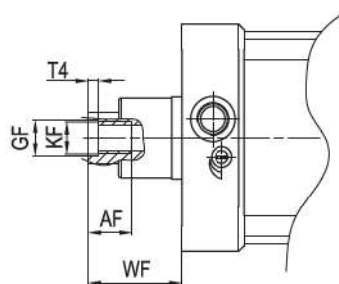

Ø mm	AF	KF	T4	WF	GF	ZJ	ZM
160	36	M20	10	80	22	260	340
200	36	M20	10	95	22	275	370
250	40	M24	12	105	26	305	410
320	50	M30	15	120	32	340	460

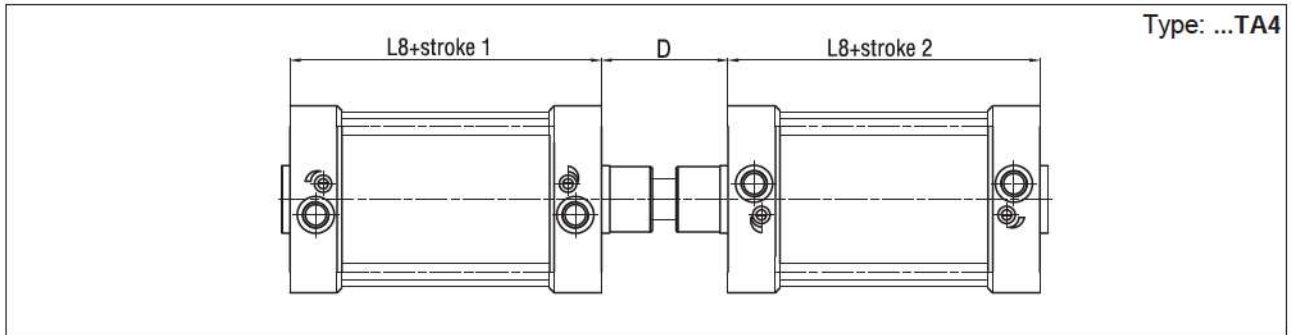
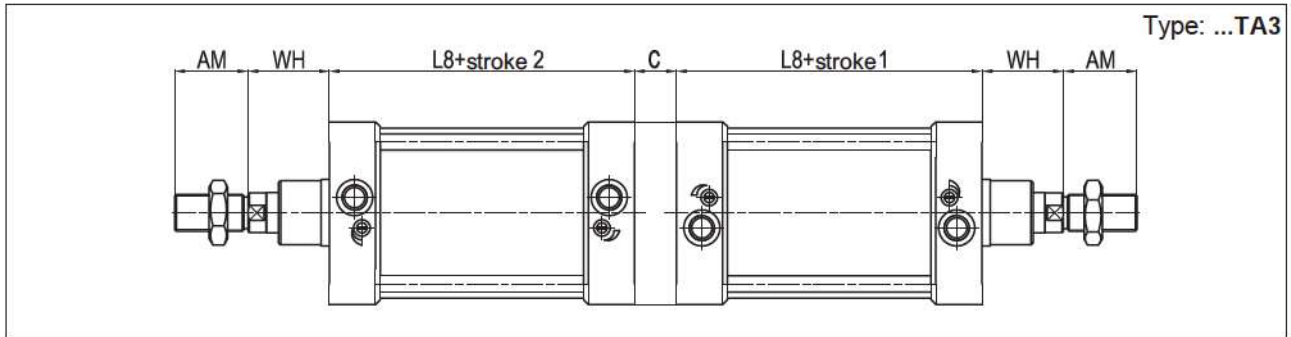
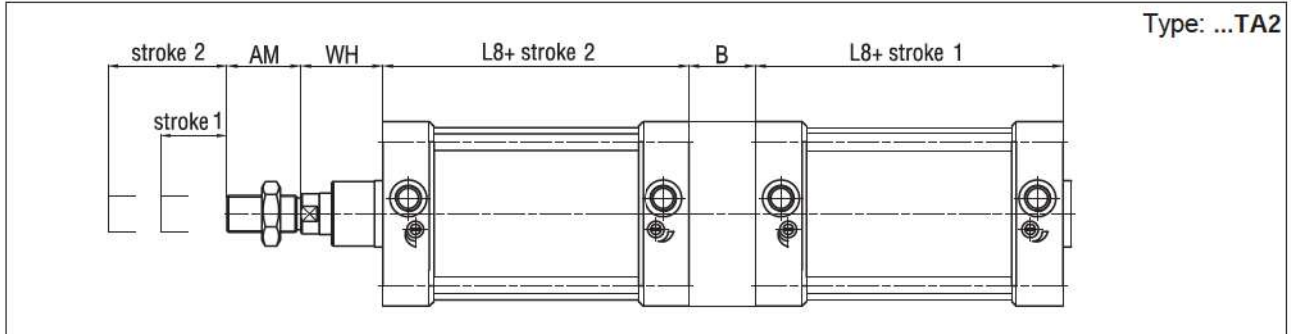
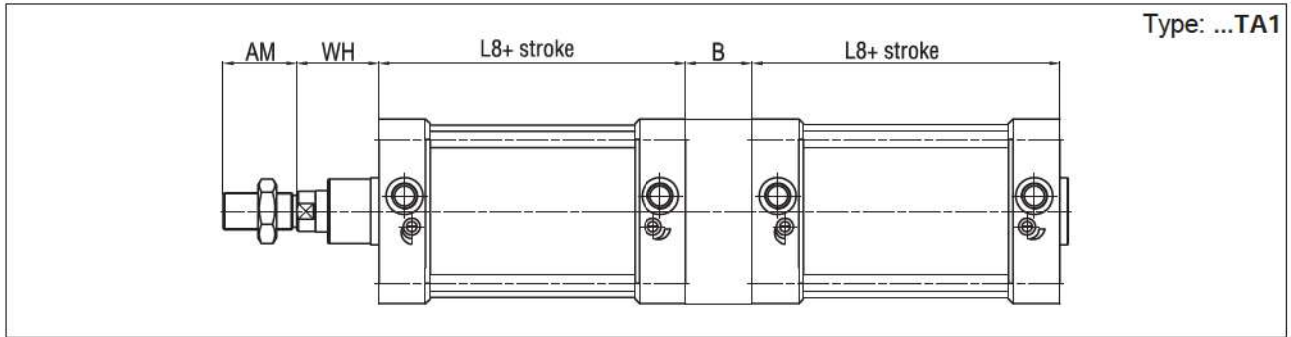

∅ mm	AM	B	C	D	L8	WH
160	72	100	50	152	180	80
200	72	130	50	167	180	95
250	84	150	60	180	200	105
320	96	180	70	200	220	120

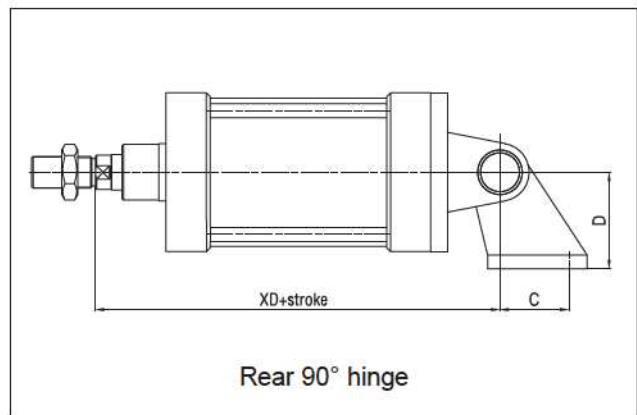
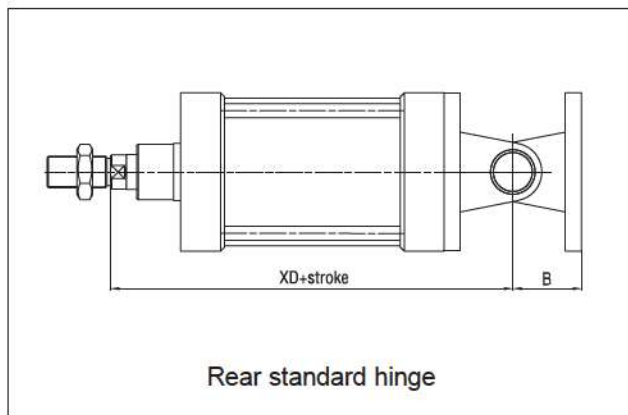
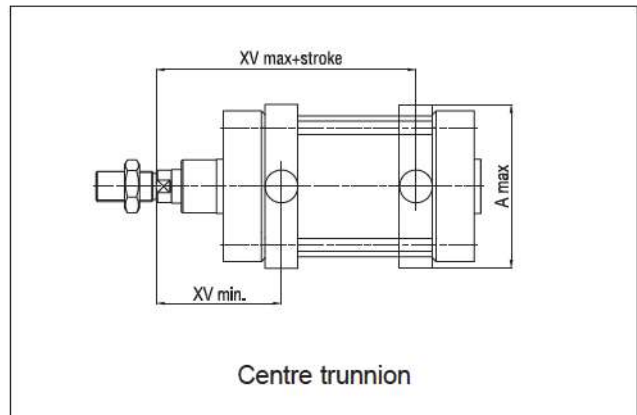
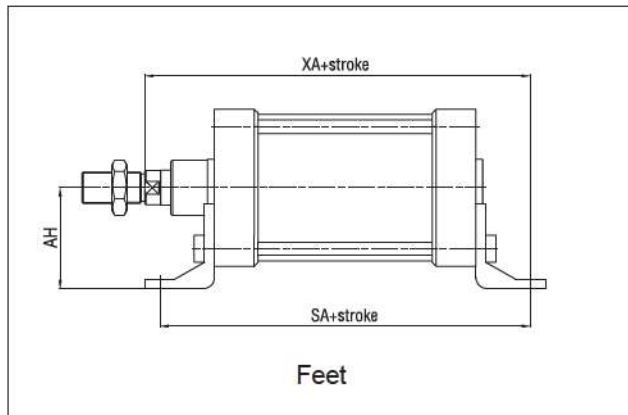
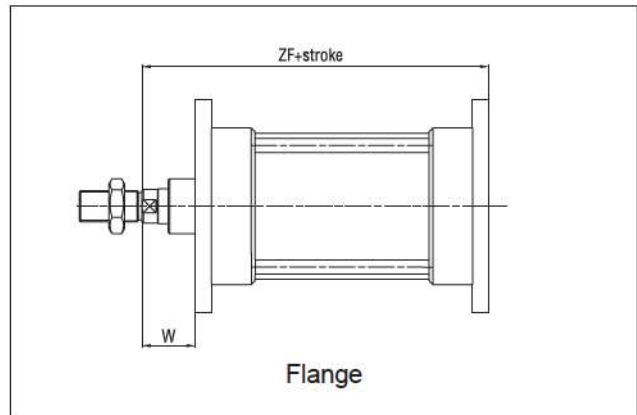
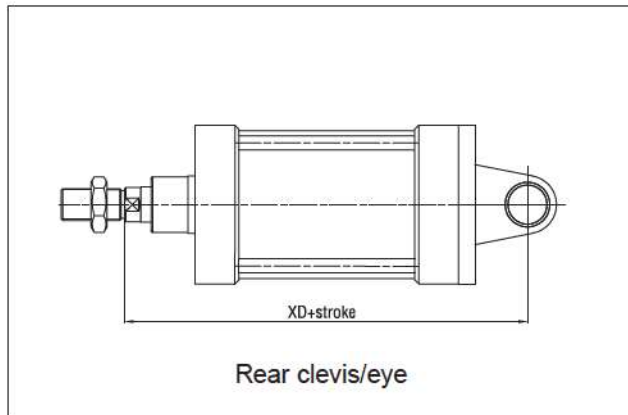

Ø mm	A max	AH	B	C	D	SA	W	XA	XD	XV min	XV max	ZF
160	190	115	55	88	115	300	60	320	315	150	190	280
200	240	135	60	90	135	320	70	345	335	165	205	300
250	296	165	70	110	165	350	80	380	375	185	225	330
320	380	200	80	122	200	390	90	425	420	207	253	370